

NEC

TFT COLOR LCD MODULE

NL128102AC23-03



39cm (15.4 Type)

SXGA

Data Sheet

(First Edition)

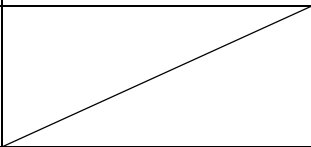
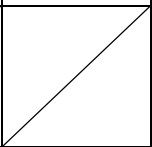
All information in this document is subject to change without prior notice.

1st Engineering Department Color LCD Division Display Device Operations Unit NEC Electron Devices NEC Corporation		
Approved		May 22, 2001
Checked		
Prepared		May 22, 2001

INTRODUCTION

No part of this SPECIFICATIONS shall be copied in any form or by any means without the prior written consent of NEC Corporation.

NEC Corporation does not assume any liability for infringement of patents, copyrights or other intellectual property rights of third parties by or arising from use of a product described herein or any other liability arising from use of such application. No license, express, implied or otherwise, is granted under any patents, copyrights or other intellectual property rights of NEC Corporation or of others.

While NEC Corporation has been making continuous effort to enhance the reliability of its products, the possibility of failures cannot be eliminated entirely. To minimize risks of damage to property or injury to person arising from a failure in an NEC product, customers must incorporate sufficient safety measures in their design, such as redundancy, fire-containment and anti-failure features.

NEC products are classified into the following three quality grades:

"Standard", "Special", "Specific"

The ***"Specific"*** quality grade applies only to applications developed based on a customer designated "quality assurance program" for a specific application. The recommended applications of a product depend on its quality grade, as indicated below. Customers must check the quality grade of each application before using it in a particular application.

Standard: Computers, office equipment, communications equipment, test and measurement equipment, audio and visual equipment, home electronic appliances, machine tools, personal electronic equipment and industrial robots

Special: Transportation equipment (automobiles, trains, ships, etc.), traffic control systems, anti-disaster systems, anti-crime systems, safety equipment and medical equipment (not specifically designed for life support)

Specific: Military systems, aircraft, aerospace equipment, submersible repeaters, nuclear reactor control systems, life support systems (medical equipment, etc.) and any other equipment

The quality grade of this product is ***"Standard"*** unless otherwise specified in this SPECIFICATIONS. If customers intend to use this product for applications other than those specified for ***"Standard"*** quality grade, they should contact an NEC Corporation sales representative in advance.

Anti-radioactive design is not implemented in this product.

CONTENTS

1. OUTLINE	P.4
2. FEATURES	P.4
3. APPLICATION	P.4
4. PRINCIPLE AND STRUCTURE	P.4
5. OUTLINE OF CHARACTERISTICS	P.5
6. BLOCK DIAGRAM	P.6
7. GENERAL SPECIFICATIONS	P.7
8. ABSOLUTE MAXIMUM RATINGS	P.7
9. ELECTRICAL CHARACTERISTICS	P.7
10. SUPPLY VOLTAGE SEQUENCE	P.8
11. INTERFACE PIN CONNECTIONS AND FUNCTIONS	P.9
12. METHOD OF CONNECTIONS FOR THC63LVDM83A	P.12
13. DISPLAY COLORS TO INPUT DATA SIGNALS	P.13
14. INPUT SIGNAL TIMINGS	P.14
15. OPTICAL CHARACTERISTICS	P.18
16. RELIABILITY TEST	P.20
17. PRECAUTIONS	P.21
18. OUTLINE DRAWINGS	
18.1 FRONT VIEW	P.23
18.2 REAR VIEW	P.24

1. OUTLINE

NL128102AC23-03 is a TFT (thin film transistor) active matrix color liquid crystal display (LCD) comprising amorphous silicon TFT attached to each signal electrode, a driving circuit and a backlight with an inverter.

This product has a 39cm (15.4 inches) display area by a diagonal, and contains 1280×1024 pixels in it. Also it can display 16,194,277 colors.

2. FEATURES

- Wide viewing angle (with Retardation Film)
- Low reflection
- LVDS interface
- High luminance
- Wide color gamut
- Incorporated edge type backlight (four lamps/ two lamps holders)
- Replaceable lamp holder

3. APPLICATION

- PC, EWS monitors

4. PRINCIPLE AND STRUCTURE

A color TFT (thin film transistor) LCD module is composed of a TFT liquid crystal panel structure, LSIs for driving the TFT array, and a backlight assembly. The TFT liquid crystal panel structure is injected liquid crystal material into the narrow gap between a TFT array glass substrate and a color filter glass substrate. Also, LCD module is connected the driver LSIs with a TFT liquid crystal panel structure, and then the backlight assembly is attached to the backside of the panel.

RGB (red, green, blue) data signals from a source system are modulated into a form suitable for active matrix addressing by the onboard signal processor and sent to the driver LSIs which in turn addresses the individual TFT cells.

Working as an electro-optical switch, each TFT cell regulates transmitted light from the backlight assembly when worked by the data source. Color images are created by regulating the amount of transmitted light through the array of red, green, and blue dots

5. OUTLINE OF CHARACTERISTICS (at room temperature)

Display area	305.28 (H) × 244.224 (V) mm
Drive system	a-Si TFT active matrix
Display colors	16,194,224 colors
Number of pixels	1280 (H) × 1024 (V)
Pixel arrangement	RGB vertical stripe
Pixel pitch	0.2385 (H) × 0.2385 (V)mm
Module size	340.0 (H, Typ.) × 269.0 (V, Typ.) × 17.9 (D, Typ.) mm
Weight	1400 g (Typ.)
Contrast ratio	250:1 (Typ.)
Viewing angle (more than the contrast ratio of 10:1)	
	- Horizontal: 70° (Typ., left side, right side)
	- Vertical: 50° (Typ., up side, down side)
Designed viewing direction	
	- Wider viewing angle without image reversal : down side
	- Optimum grayscale ($\gamma=2.2$) : perpendicular
	- Viewing angle with maximum contrast ratio : down side (10°)
Polarizer Pencil-hardness	3 H (Min., at JIS K5400)
Color gamut	60 % (Typ., at center, To NTSC)
Response time	6 ms (Typ.), "white" to "black" (100% → 10%)
Luminance	240 cd/m ² (Typ., at IL= 6mArms/ lamp)
Signal system	2 ports LVDS interface (THC63LVDF84A×2pcs, THine Electronics, Inc.) RGB 8-bit signals, Synchronous signals (Hsync, Vsync), Data enable signal (DE)
Supply voltage	12V (Logic, LCD driving), 12V (Backlight)
Backlight	Edge light type: Four cold cathode fluorescent lamps in two lamp holders, Inverter-less [Replaceable parts] - Lamp holder: 154LHS04
Power consumption	19 W (Typ.) (Checker flag pattern, at IL= 6mA / lamp)

6. BLOCK DIAGRAM

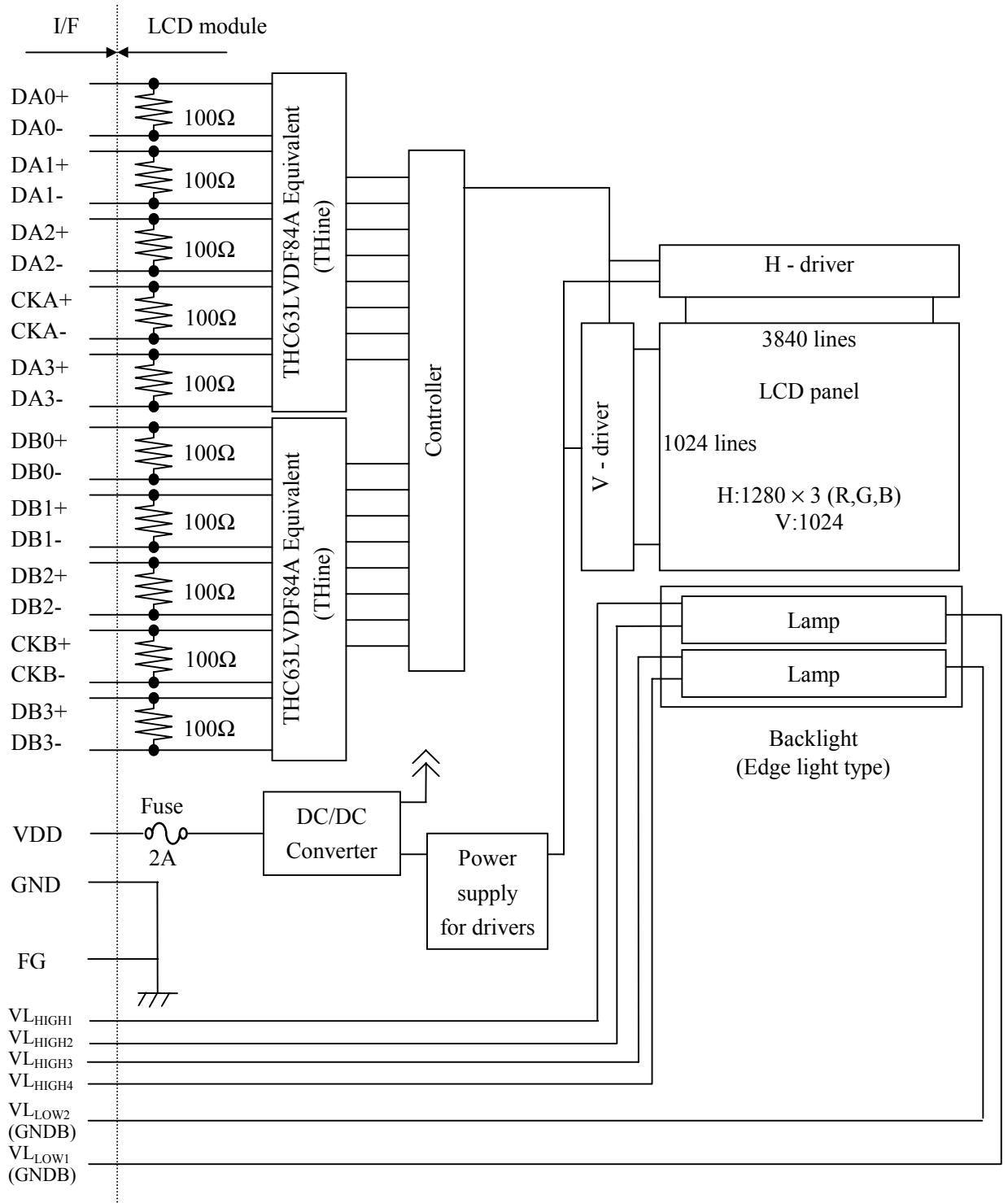

Note1: GND (Signal Ground) is connected to FG (Frame Ground) in the LCD module. Neither GND nor FG is connected to GNDB (Backlight Ground). These grounds should be connected to system ground in customer equipment.

7. GENERAL SPECIFICATIONS

Item	Specification	Unit
Module size	340.0±1.0 (H) × 269.0±1.0 (V) × 17.9+0.1/-0.2 (D) Note 1	mm
Display area	305.28 (H) × 244.224 (V) [Diagonal display size: 39cm (Type 15.4)]	mm
Number of pixels	1280 (H) × 1024 (V)	pixel
Dot pitch	0.0795 (H) × 0.2385 (V)	mm
Pixel pitch	0.2385 (H) × 0.2385 (V)	mm
Pixel arrangement	RGB (Red, Green, Blue) vertical stripe	-
Display colors	16,194,277	color
Weight	1400 (Typ.), 1520 (Max.)	g

Note 1: Wrinkles and bending of a transparency sheet are excepted.

8. ABSOLUTE MAXIMUM RATINGS

Parameter	Symbol	Rating	Unit	Remarks
Supply voltage	VDD	-0.3 to +14.0	V	Ta = 25°C
LVDS input voltage	Vi	-0.3 to 3.6	V	Ta = 25°C VDD=12V
Lamp voltage	VL	2000	Vrms	Ta = 25°C
Storage temperature	Tst	-20 to +60	°C	-
Operating temperature	Top1	0 to +50	°C	Module front surface Note 1
	Top2	0 to +60	°C	Module rear surface Note 2
Relative humidity (RH) Note 3		≤ 95	%	Ta ≤ 40°C
		≤ 85	%	40°C < Ta ≤ 50°C
Absolute humidity Note 3	Note 3	≤ 78 Note 4	g/m ³	Ta > 50°C

Note 1: Measured at the surface of display area (including self-heat)

Note 2: Measured at the rear shield (including self-heat)

Note 3: No condensation

Note 4: Ta = 55°C, RH = 70%

9. ELECTRICAL CHARACTERISTICS

(1) Controller / LCD driving

Ta = 25°C

Parameter	Symbol	Min.	Typ.	Max.	Unit	Remarks
Supply voltage	VDD	11.4	12.0	12.6	V	-
Ripple voltage	VRP	-	-	+100	mV	for VDD
Differential input "L" Threshold voltage	VTL	-100	-	-	mV	VCM=1.2V
Differential input "H" Threshold voltage	VTH	-	-	+100	mV	VCM: Common mode voltage in LVDS driver
Input voltage width	VI	0	-	2.4	V	-
Terminating resistor	RT	-	100	-	Ω	-
Supply current	IDD	-	270 Note 1	450 Note 2	mA	VDD=12.0V

Note 1: Checker flag pattern (in EIAJ ED-2522)

Note 2: Theoretical maximum current pattern

(2) Backlight

(Ta = 25°C)

Parameters	Symbols	Min.	Typ.	Max.	Units	Remarks
Lamp current	IL	3.0	6.0	7.0	mArms	for each lamp
Lamp voltage	VL	-	650	-	Vrms	-
Lamp turn on voltage	VS	1050	-	-	Vrms	Ta = 25°C
Note 1		1450	-	-	Vrms	Ta = 0°C
Oscillator frequency	Ft	50	-	60	kHz	Note 2

Note1: When IL and/or VS are lower than Min. value, lamps will not turn on.

Note2: Recommended value of 'Ft'

- 1) 'Ft' should be within the specification.
and

$$2) Ft = 1/4th \times (2n-1) \quad th: \text{Hsync period} \\ n: \text{a natural number (1,2,3...)}$$

If Ft is not the recommended value, Beat noise may appear on the screen, because of interference between Ft frequency and Hsync frequency.

Note3: The lamp current should be measured by high-frequency current meter at the low voltage terminal. Two lamps contain in the one lamp holder, and both lamps are connected to one low voltage cable. Therefore, the lamp current at low voltage terminal is sum of two lamps (12mA Typ.)

Note4: The inverter power supply has a big influence on lighting-up characteristics and the lifetime of the lamp. When design the inverter power supply, evaluate it sufficiently.

(3) Fuse

This LCD module uses fuse shown below.

	Part No.	Suppliers	Ratings	Remarks
VDD	CCF16 202AD	KAMAYA ELECTRIC CO.,LTD	32V/2A	Note 1

Note1: The power capacity should be more than 2 times of fuse ratings from safety point of view. If the power capacity of your system is less than above request, check and evaluate it carefully.

10. SUPPLY VOLTAGE SEQUENCE

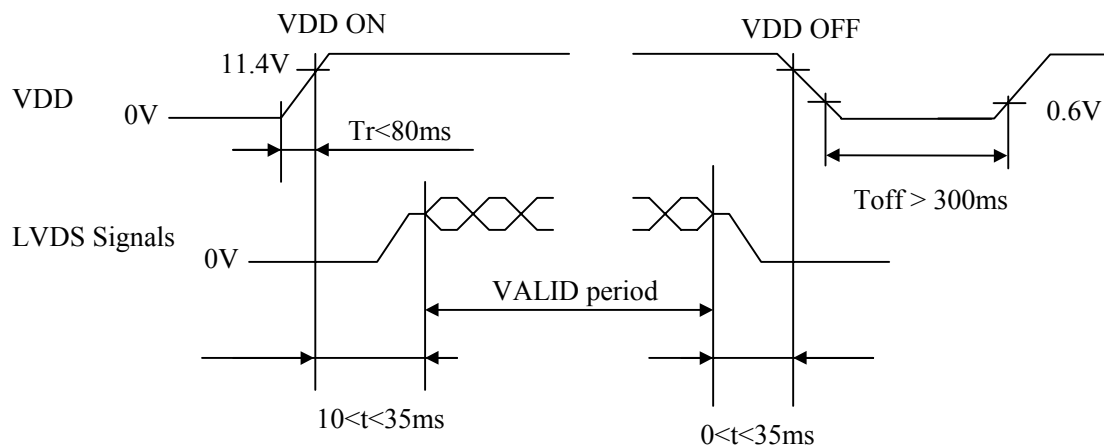

Note1: LVDS signals should be measured at the terminal of 100Ω resistor.

Note2: When turn on the LCD module, if VCC voltage falls down during the rising period up to 11.4V, the LCD module may not start to work because of the protection circuit.

Note3: The backlight should be turned ON/OFF when LVDS signals are coming. Otherwise, unstable data may be displayed when the backlight power is turned ON/OFF.

11. INTERFACE PIN CONNECTIONS AND FUNCTIONS

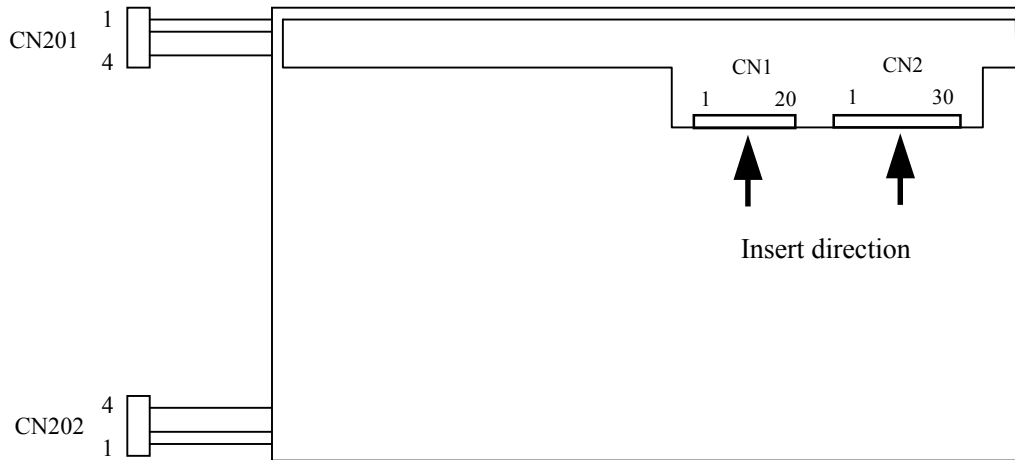

(1) Interface connector for signal and power

CN1 socket: 53780-2090
 Adaptable plug: 51146-2000
 Supplier: Molex Incorporated.

Pin No.	Symbol	Function	Description
1	N.C.	Non-connection	Keep the terminal open
2	N.C.		
3	GND	Ground	Connect to system ground Note 1
4	GND		
5	DA0-	Odd pixel Data0	LVDS differential signal Note 2
6	DA0+		
7	GND	Ground	Connect to system ground Note 1
8	DA1-	Odd pixel Data1	LVDS differential signal Note 2
9	DA1+		
10	GND	Ground	Connect to system ground Note 1
11	DA2-	Odd pixel Data2	LVDS differential signal Note 2
12	DA2+		
13	GND	Ground	Connect to system ground Note 1
14	CKA-	Odd pixel Clock	LVDS differential signal Note 2
15	CKA+		
16	GND	Ground	Connect to system ground Note 1
17	DA3-	Odd pixel Data3	LVDS differential signal Note 2
18	DA3+		
19	GND	Ground	Connect to system ground Note 1
20	N.C.	Non-connection	Keep the terminal open

Note1: GND is signal ground for Controller. GND is connected to FG (Frame Ground) in the LCD module. Neither GND nor FG is connected to GNDB (Backlight Ground). These grounds should be connected to system ground in customer equipment.

Note2: Use 100Ω twist pair wires for the cable.

Note3: Do not keep pins free (except 1,2 and 20) to avoid noise problem.

CN1: Figure of socket

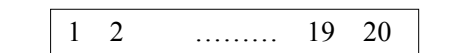

CN2 socket: 53780-3090
 Adaptable plug: 51146-3000
 Supplier: Molex Incorporated.

Pin No.	Symbol	Function	Description
1	N.C.	Non-connection	Keep the terminal open
2	N.C.		
3	GND	Ground	Connect to system ground Note 1
4	GND		
5	DB0-	Even Pixel Data0	LVDS differential signal Note 2
6	DB0+		
7	GND	Ground	Connect to system ground Note 1
8	DB1-	Even Pixel Data1	LVDS differential signal Note 2
9	DB1+		
10	GND	Ground	Connect to system ground Note 1
11	DB2-	Even Pixel Data2	LVDS differential signal Note 2
12	DB2+		
13	GND	Ground	Connect to system ground Note 1
14	CKB-	Even Pixel Clock	LVDS differential signal Note 2
15	CKB+		
16	GND	Ground	Connect to system ground Note 1
17	DB3-	Even Pixel Data3	LVDS differential signal Note 2
18	DB3+		
19	GND	Ground	Connect to system ground Note 1
20	Reserved	Reserved	Keep the terminal open
21	Reserved		
22	Reserved		
23	Reserved		
24	GND	Ground	Connect to system ground Note 1
25	GND		
26	GND		
27	N.C.	Non-connection	Keep the terminal open
28	VDD	+12V Power Supply	12V±5%
29	VDD		
30	VDD		

Note1: GND is signal ground for Controller. GND is connected to FG (Frame Ground) in the LCD module. Neither GND nor FG is connected to GNDB (Backlight Ground). These grounds should be connected to system ground in customer equipment.

Note2: Use 100Ω twist pair wires for the cable.

Note3: Do not keep pins free (except 1,2,20-23 and 27) to avoid noise problem.

CN2: Figure of socket

1	2	29	30
---	---	-------	----	----

(2) Connector for backlight lamp

CN201 plug: BHR-04VS-1
 Adaptable socket: SM03(7-D1)B-BHS-1
 Supplier: HIROSE ELECTRIC CO., LTD.

Pin No.	Symbol	Function	Description
1	VL _{HIGH1}	Upper side lamp, High voltage terminal	The cable color is pink Note 1
2	VL _{HIGH2}	Upper side lamp, High voltage terminal	The cable color is pink
3	N.C.	Non-connection	Keep the terminal open.
4	VL _{LOW1} (GNDB)	Up side lamp, Low voltage terminal	The cable color is gray

CN202 plug: BHR-04VS-1
 Adaptable socket: SM03(7-D1)B-BHS-1
 Supplier: J.S.T. TRADING COMPANY, LTD.

Pin No.	Symbol	Function	Description
1	VL _{HIGH3}	Lower side lamp, High voltage terminal	The cable color is pink
2	VL _{HIGH4}	Lower side lamp, High voltage terminal	The cable color is pink
3	N.C.	Non-connection	Keep the terminal open.
4	VL _{LOW2} (GNDB)	Lower side lamp, Low voltage terminal	The cable color is gray

Note 1: GND (signal ground) is connected to FG (frame ground) in the LCD module. Neither GND nor FG is connected to GNDB (backlight ground). These grounds should be connected to system ground in customer equipment.

Attention: VL_{HIGH} and VL_{LOW} must be connected correctly. If customer connects wrongly, customer will be hurt and the module will be broken.

12. METHOD OF CONNECTION FOR THC63LVDM83A

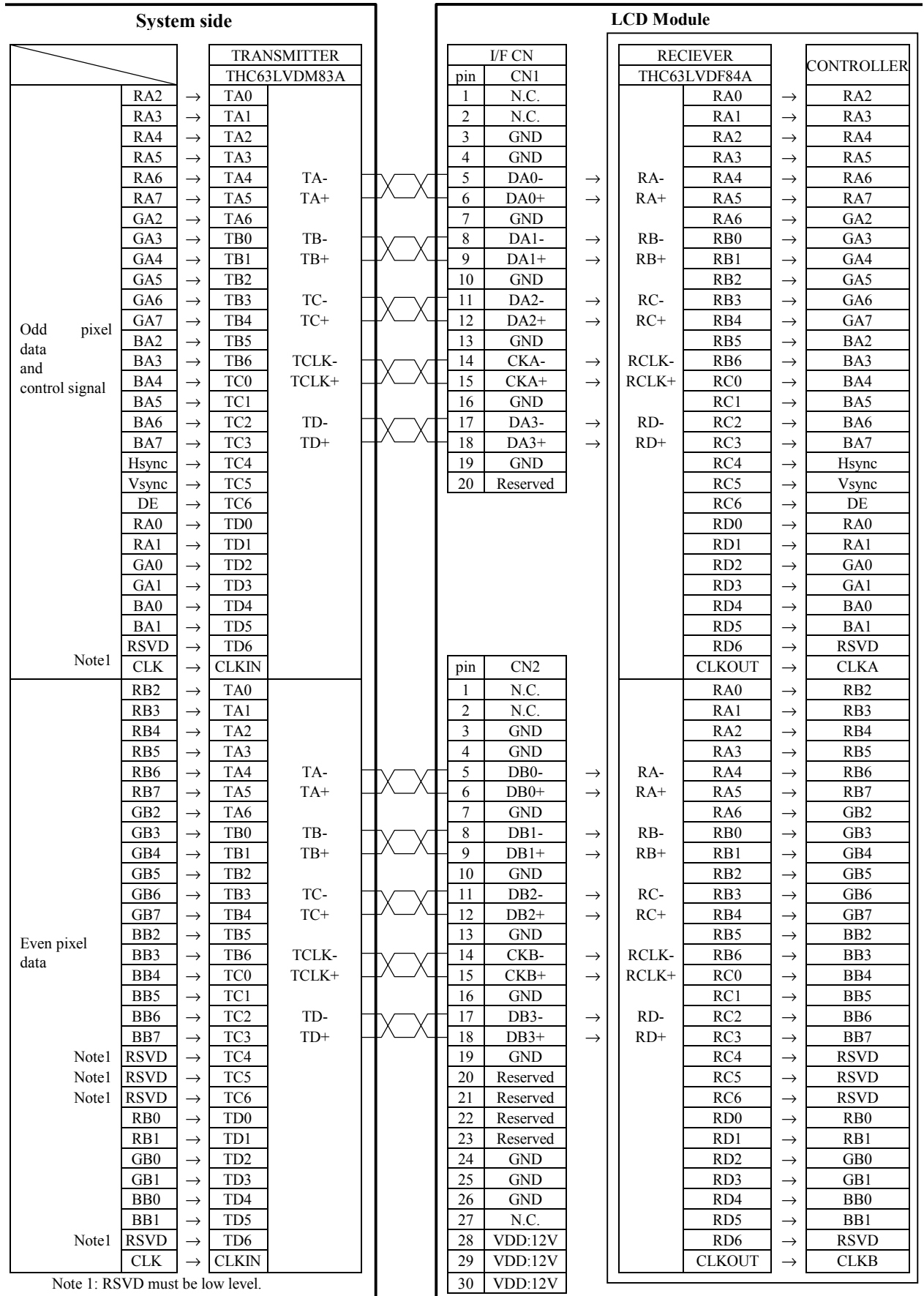

13. DISPLAY COLORS TO INPUT DATA SIGNALS

Display colors		Data signal (0: Low level, 1: High level)																														
		RA7	RA6	RA5	RA4	RA3	RA2	RA1	RA0	GA7	GA6	GA5	GA4	GA3	GA2	GA1	GA0	BA7	BA6	BA5	BA4	BA3	BA2	BA1	BA0							
		RB7	RB6	RB5	RB4	RB3	RB2	RB1	RB0	GB7	GB6	GB5	GB4	GB3	GB2	GB1	GB0	BB7	BB6	BB5	BB4	BB3	BB2	BB1	BB0							
Basic colors	Black	0	0	0	0	0	0	0	0	0	0	0	0	0	0	0	0	0	0	0	0	0	0	0	0							
	Blue	0	0	0	0	0	0	0	0	0	0	0	0	0	0	0	0	$\left. \begin{matrix} 1 & 1 & 1 & 1 & 1 & 1 & 0 & 1 \\ 1 & 1 & 1 & 1 & 1 & 1 & 1 & 0 \\ 1 & 1 & 1 & 1 & 1 & 1 & 1 & 1 \end{matrix} \right\}$														
	Red	$\left. \begin{matrix} 1 & 1 & 1 & 1 & 1 & 1 & 0 & 1 \\ 1 & 1 & 1 & 1 & 1 & 1 & 1 & 0 \\ 1 & 1 & 1 & 1 & 1 & 1 & 1 & 1 \end{matrix} \right\}$								0	0	0	0	0	0	0	0	0	0	0	0	0	0	0	0							
	Magenta	$\left. \begin{matrix} 1 & 1 & 1 & 1 & 1 & 1 & 0 & 1 \\ 1 & 1 & 1 & 1 & 1 & 1 & 1 & 0 \\ 1 & 1 & 1 & 1 & 1 & 1 & 1 & 1 \end{matrix} \right\}$								0	0	0	0	0	0	0	0	$\left. \begin{matrix} 1 & 1 & 1 & 1 & 1 & 1 & 0 & 1 \\ 1 & 1 & 1 & 1 & 1 & 1 & 1 & 0 \\ 1 & 1 & 1 & 1 & 1 & 1 & 1 & 1 \end{matrix} \right\}$														
	Green	0	0	0	0	0	0	0	0	$\left. \begin{matrix} 1 & 1 & 1 & 1 & 1 & 1 & 0 & 1 \\ 1 & 1 & 1 & 1 & 1 & 1 & 1 & 1 \\ 1 & 1 & 1 & 1 & 1 & 1 & 1 & 1 \end{matrix} \right\}$								0	0	0	0	0	0	0	0	0	0	0	0	0	0	0
	Cyan	0	0	0	0	0	0	0	0	$\left. \begin{matrix} 1 & 1 & 1 & 1 & 1 & 1 & 0 & 1 \\ 1 & 1 & 1 & 1 & 1 & 1 & 1 & 0 \\ 1 & 1 & 1 & 1 & 1 & 1 & 1 & 1 \end{matrix} \right\}$								$\left. \begin{matrix} 1 & 1 & 1 & 1 & 1 & 1 & 0 & 1 \\ 1 & 1 & 1 & 1 & 1 & 1 & 1 & 0 \\ 1 & 1 & 1 & 1 & 1 & 1 & 1 & 1 \end{matrix} \right\}$														
	Yellow	$\left. \begin{matrix} 1 & 1 & 1 & 1 & 1 & 1 & 0 & 1 \\ 1 & 1 & 1 & 1 & 1 & 1 & 1 & 0 \\ 1 & 1 & 1 & 1 & 1 & 1 & 1 & 1 \end{matrix} \right\}$								$\left. \begin{matrix} 1 & 1 & 1 & 1 & 1 & 1 & 0 & 1 \\ 1 & 1 & 1 & 1 & 1 & 1 & 1 & 0 \\ 1 & 1 & 1 & 1 & 1 & 1 & 1 & 1 \end{matrix} \right\}$								0	0	0	0	0	0	0	0	0	0	0	0	0	0	0
	White	$\left. \begin{matrix} 1 & 1 & 1 & 1 & 1 & 1 & 0 & 1 \\ 1 & 1 & 1 & 1 & 1 & 1 & 1 & 0 \\ 1 & 1 & 1 & 1 & 1 & 1 & 1 & 1 \end{matrix} \right\}$								$\left. \begin{matrix} 1 & 1 & 1 & 1 & 1 & 1 & 0 & 1 \\ 1 & 1 & 1 & 1 & 1 & 1 & 1 & 0 \\ 1 & 1 & 1 & 1 & 1 & 1 & 1 & 1 \end{matrix} \right\}$								$\left. \begin{matrix} 1 & 1 & 1 & 1 & 1 & 1 & 0 & 1 \\ 1 & 1 & 1 & 1 & 1 & 1 & 1 & 0 \\ 1 & 1 & 1 & 1 & 1 & 1 & 1 & 1 \end{matrix} \right\}$														
Red grayscale	Black	0	0	0	0	0	0	0	0	0	0	0	0	0	0	0	0	0	0	0	0	0	0	0	0							
	Dark	0	0	0	0	0	0	0	1	0	0	0	0	0	0	0	0	0	0	0	0	0	0	0	0							
	↑					:								:							:											
	↓					:								:							:											
	Bright	1	1	1	1	1	1	0	0	0	0	0	0	0	0	0	0	0	0	0	0	0	0	0	0							
Red	$\left. \begin{matrix} 1 & 1 & 1 & 1 & 1 & 1 & 0 & 1 \\ 1 & 1 & 1 & 1 & 1 & 1 & 1 & 0 \\ 1 & 1 & 1 & 1 & 1 & 1 & 1 & 1 \end{matrix} \right\}$								0	0	0	0	0	0	0	0	0	0	0	0	0	0	0									
Green grayscale	Black	0	0	0	0	0	0	0	0	0	0	0	0	0	0	0	0	0	0	0	0	0	0	0	0							
	Dark	0	0	0	0	0	0	0	0	0	0	0	0	0	0	1	0	0	0	0	0	0	0	0	0							
	↑					:								:							:											
	↓					:								:							:											
	Bright	0	0	0	0	0	0	0	0	1	1	1	1	1	1	0	0	0	0	0	0	0	0	0	0							
Green	0	0	0	0	0	0	0	0	$\left. \begin{matrix} 1 & 1 & 1 & 1 & 1 & 1 & 0 & 1 \\ 1 & 1 & 1 & 1 & 1 & 1 & 1 & 0 \\ 1 & 1 & 1 & 1 & 1 & 1 & 1 & 1 \end{matrix} \right\}$								0	0	0	0	0	0	0	0	0	0	0	0	0	0		
Blue grayscale	Black	0	0	0	0	0	0	0	0	0	0	0	0	0	0	0	0	0	0	0	0	0	0	0	0							
	Dark	0	0	0	0	0	0	0	0	0	0	0	0	0	0	0	0	0	0	0	0	0	0	0	1							
	↑					:								:							:											
	↓					:								:							:											
	Bright	0	0	0	0	0	0	0	0	0	0	0	0	0	0	0	0	1	1	1	1	1	1	0	0							
Blue	0	0	0	0	0	0	0	0	0	0	0	0	0	0	0	0	$\left. \begin{matrix} 1 & 1 & 1 & 1 & 1 & 1 & 0 & 1 \\ 1 & 1 & 1 & 1 & 1 & 1 & 1 & 0 \\ 1 & 1 & 1 & 1 & 1 & 1 & 1 & 1 \end{matrix} \right\}$															

Note1: The combination of 8-bit signals (253 steps in grayscale) results in equivalent to 16,194,277 (253×253×253) colors.

The display data of (11111101), (11111110) and (11111111) become same grayscale.

14. INPUT SIGNAL TIMINGS

(1) Input signal specifications

	Parameter		Symbol	Min.	Typ.	Max.	Unit	Remarks
CLK	Frequency	Vf=75Hz	1/ tc	65.0	67.5	70.0	MHz	-
		Vf=60Hz		-	14.815	-	ns	
	Duty	tc / tcl	Note 1	51.5	54.0	56.5	MHz	
				-	18.52	-	ns	
Rise, fall	tcrf					ns	-	
Hsync	Period	Vf=75Hz	th	12.3	12.504	-	μs	Typ=80.0kHz Note2,3
		Vf=60Hz		750	844	-	CLK	
	Period	th	th	12.3	15.630	-	μs	Typ=64.0kHz
				750	844	-	CLK	
	Display period		thd	640			CLK	-
	Front-porch		thf	-	-	-	CLK	-
	Pulse width	Vf=75Hz	thp *	-	72	-	CLK	-
		Vf=60Hz		-	56	-	CLK	
	Back-porch		thb *	-	124	-	CLK	-
	* thp + thb			110	-	-	CLK	-
CLK-Hsync set-up		ths	Note1			ns		
CLK-Hsync hold		thh				ns		
Raise,fall		thrf				ns		
Vsync	Period	Vf=75Hz	tv	-	13.329	14.47	ms	Typ=75.0Hz
		Vf=60Hz		1028	1066	-	H	
	Period	tv	tv	-	16.661	14.47	ms	Typ=60.0Hz
				1028	1066	-	H	
	Display period		tvd	1024			H	-
	Front-porch		tvf *	-	1	-	H	-
	Pulse width		tvp *	-	3	-	H	-
	Back-porch		tvb *	-	38	-	H	-
	* tvp + tvb + tvf			4	-	-	H	-
	Hsync-Vsync set-up		thvs	1	-	-	CLK	-
	Hsync-Vsync hold		thvh	1	-	-	CLK	-
	CLK-Vsync set-up		tvs	Note1			ns	-
CLK-Vsync hold		tvh	ns				-	
Raise,fall		tvrf	ns				-	
DE	CLK-DE set-up		tdes	Note1			ns	-
	CLK-DE hold		tdeh				ns	-
	Raise,fall		tderf				ns	-
DATA	CLK-DATA set-up		tds	Note1			ns	-
	CLK-DATA hold		tdh				ns	-
	Raise, fall		tdrf				ns	-

Note1: Timing specifications are defined by the input signals of LVDS transmitter.

THC63LVDM83A (THine) or equivalent products are recommended for LVDS transmitter.

Note 2: Both of "time" and "CLK number" of the "th" must keep the Minimum value of specification.

Note 3: During operation, fluctuation of Hsync period must not exceed ± 1 CLK. Otherwise function errors will occur in LCD module.

e.g.: Acceptable fluctuation range is 843-845 CLK, when the Hsync period is 844 CLK.

(2) Input signals timing chart for LCD

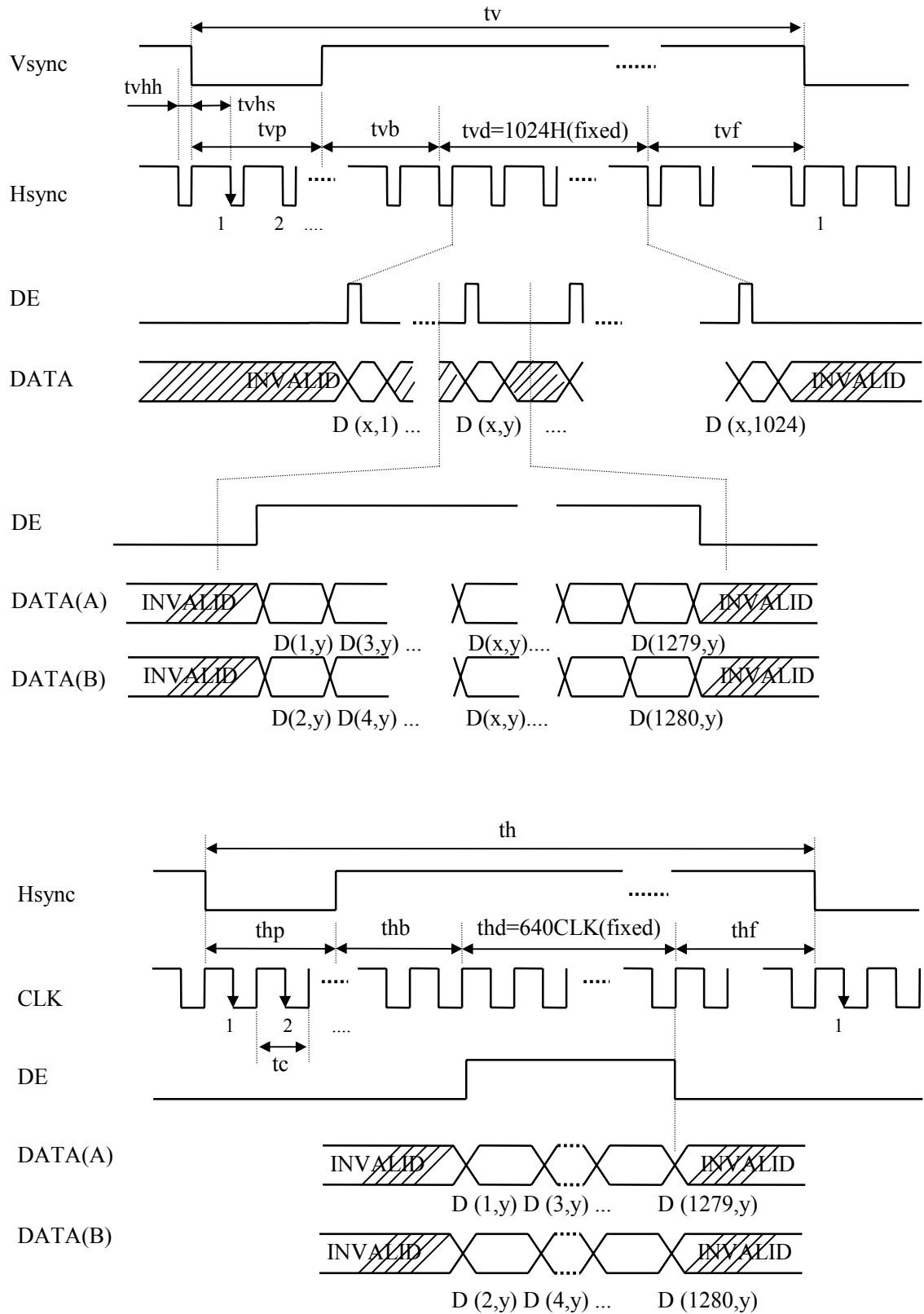

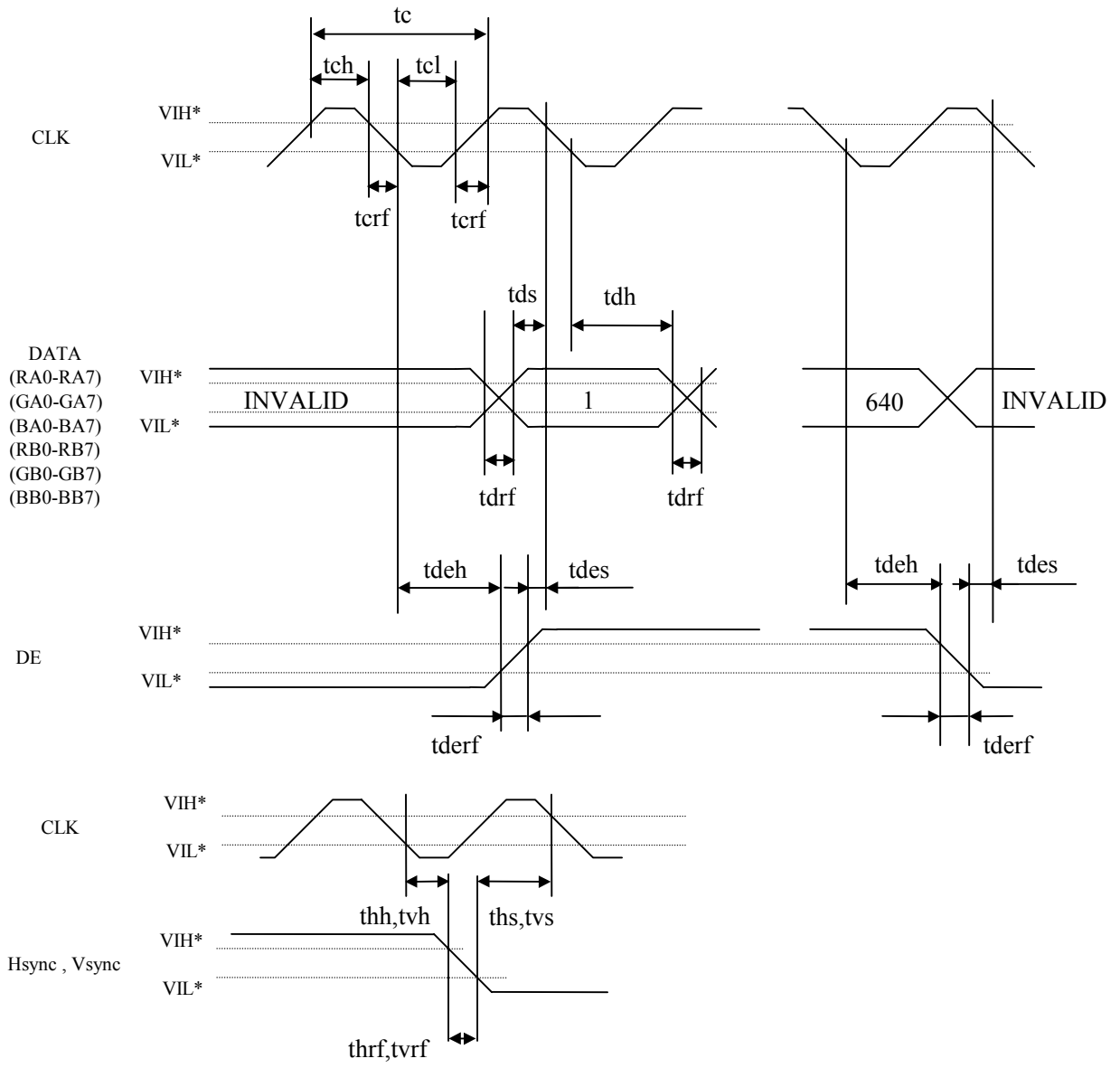

* See the specifications of LVDS manufactures for detailed design.

(3) Display positions of input data

Odd Pixel: RA= R DATA Even Pixel : RB=R DATA
 Odd Pixel: GA= G DATA Even Pixel : GB=G DATA
 Odd Pixel: BA= B DATA Even Pixel : BB=B DATA

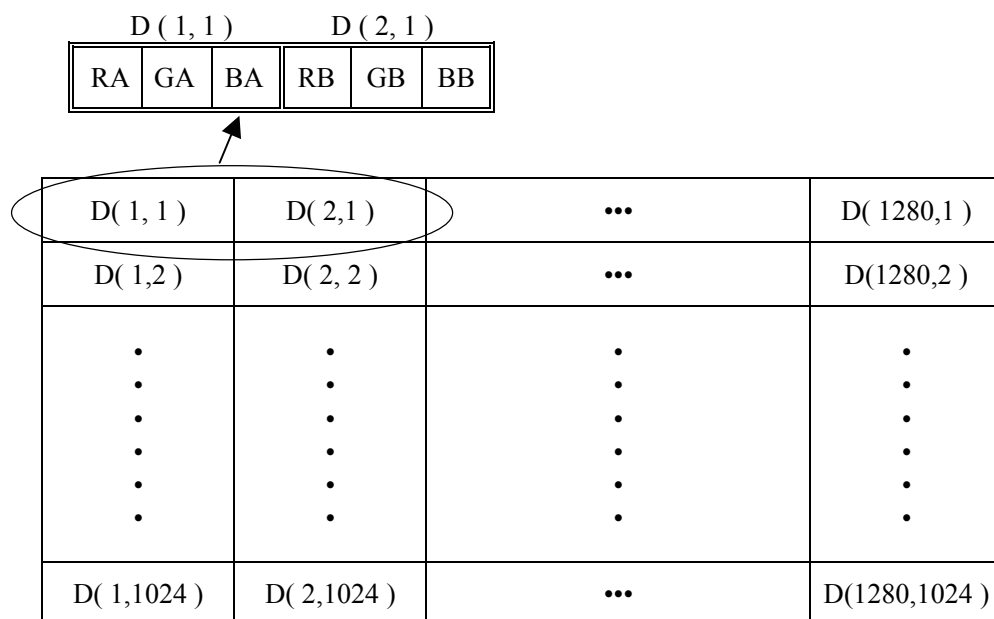

15. OPTICAL CHARACTERISTICS

(Ta =25°C, VDD=12V, VDDB=12V, Note 1)

Parameter	Symbol	Condition		Min.	Typ.	Max.	Unit	Remarks
Contrast ratio	CR	Note 2		150	250	-	-	Note 3
Luminance	Lvmax	White, Note 2		180	240	-	cd/m ²	-
Luminance uniformity	-	Max. / Min.		-	1.2	1.3	-	Note 6
Chromaticity Coordinates	W	White (x, y)		-	0.31, 0.32	-	-	Note 2
	R	Red (x, y)		-	0.62, 0.34	-	-	
	G	Green (x, y)		-	0.31, 0.57	-	-	
	B	Blue (x, y)		-	0.15, 0.09	-	-	
Color gamut	C	$\theta R=0^\circ, \theta L=0^\circ, \theta U=0^\circ, \theta D=0^\circ$ at center, to NTSC		50	60	-	%	
Viewing angle range (CR>10)	θ_{x+}	CR > 10, White/Black		60	70	-	deg.	Note 4
	θ_{x-}	$\theta_{y\pm}=0^\circ$		60	70	-	deg.	
	θ_{y+}	CR > 10, White/Black		35	50	-	deg.	
	θ_{y-}	$\theta_{x\pm}=0^\circ$		35	50	-	deg.	
Response time (Module surface temperature =30°C)	Ton	Black to White	0% → 90%	-	41	60	ms	Note 5
	Toff	White to Black	100% → 10%	-	6	12	ms	Note 5

Note1: Measurement conditions

Optical characteristics are measured after 20minutes from lighting the backlight with all pixels in white, in the dark room. The typical value is measured after luminance saturation.

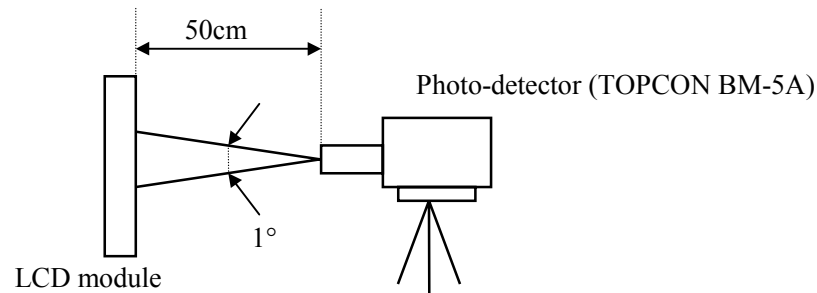

Note 2: Viewing angle is $\theta_x = \pm 0^\circ, \theta_y = \pm 0^\circ$, at center

Note 3: The contrast ratio is calculated by using the following formula.

$$\text{Contrast ratio (CR)} = \frac{\text{Luminance with all pixels in "white"}}{\text{Luminance with all pixels in "black"}}$$

Note 4: Definitions of viewing angle are as follows.

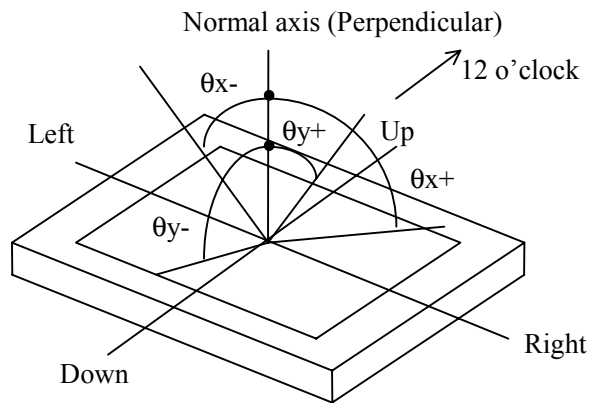

Note 5: Definition of response time are as follows.

Response time is measured by photo-detector's out put level, when the luminance change "white" to "black", or "black" to "white" on the same screen point. Ton is the time it takes the luminance to go from 100% on condition to 10% on condition. Toff is the time it takes luminance to go from 0% on condition to 90% on condition. (See the following diagram.)

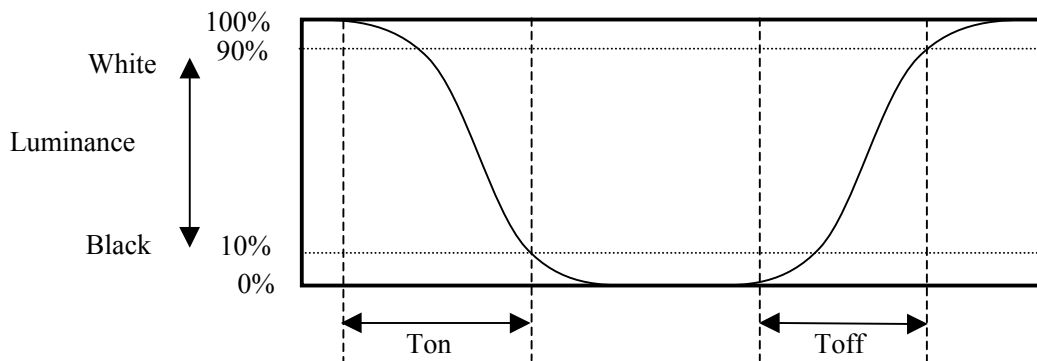

Note 6: The luminance uniformity is calculated by using following formula.

$$\text{Luminance uniformity} = \frac{\text{Maximum Luminance}}{\text{Minimum Luminance}}$$

The luminance is measured at near the five points shown below.

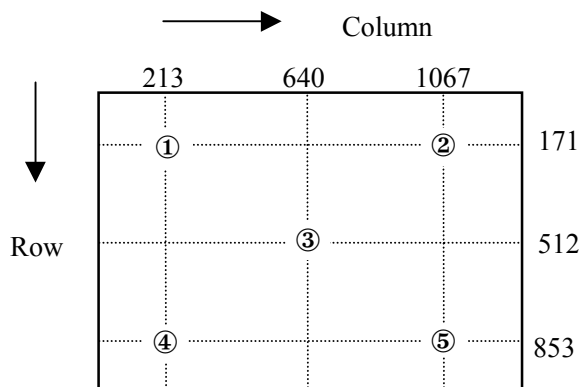

16. RELIABILITY TEST

Test item	Test condition	Judgment
High temperature / humidity operation	50±2°C, RH= 85% 240 hours, Display data is black.	Note 1
Heat cycle (operation)	① 0°C±3°C --- 1 hour 55°C±3°C --- 1 hour ② 50 cycles , 4 hours / cycle ③ Display data is black.	Note 1
Thermal shock (non-operation)	① -20°C±3°C --- 30 minutes 60°C±3°C --- 30 minutes ② 100 cycles ③ Temperature transition time is within 5 minutes.	Note 1
Vibration (non-operation)	① 5-100Hz, 19.6m/s ² (2G) 1 minute / cycle, X,Y,Z direction ② 50 times each direction	Note 1 Note 2
Mechanical shock (non-operation)	① 294 m/s ² (30G), 11ms X,Y,Z direction ② 3 times each direction	Note 1 Note 2
ESD (operation)	150pF, 150Ω, ±10kV 9 places on a panel Note 3 10 times each place at one-second intervals	Note 1
Dust (operation)	15 kinds of dust (JIS-Z 8901) Hourly 15 seconds stir, 8 times repeat	Note 1

Note1: No display malfunctions (Display functions are checked under the same conditions as outgoing inspection.)

Note2: No physical damages

Note3: See the following figure for discharge points

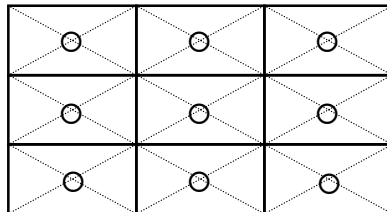

17. PRECAUTIONS

17.1 MEANING OF CAUTION SIGNS

The following caution signs have very important meaning. **Be sure to understand following contents, respectively.**



This sign has a meaning that customer will be injured himself and/or the product will sustain a damage, if customer makes a mistake in operations.



This sign has a meaning that customer will get an electric shock, if customer makes a mistake in operations.



This sign has a meaning that customer will be injured himself, if customer makes a mistake in operations.

17.2 CAUTIONS



Do not touch HIGH VOLTAGE PART of the inverter while turn on. Customer will be in danger of an electric shock.



- * Pay attention to handling for the working backlight. It may be over 35°C from ambient temperature.
- * Do not shock and press the LCD panel and the backlight. There will be in danger of breaking, because they are made of glass. (Shock: To be not greater 294m/s² (30G) and to be not greater 11ms, Pressure: To be not greater 19.6N (2kgf))

17.3 ATTENTIONS

(1) Handling the product

- ① When customer pulls out products from carton box, take hold of both ends without touch the circuit board. If customer touches it, products may be broken down and/or out of adjustment, because of stress to mounting parts.
- ② If customer places products temporarily, turn down the display side and place on a flat table.
- ③ Handle products with care and avoid electrostatic discharge (e.g. Decrease with earth band, ionic shower, etc.), because products (LCD modules) may be damaged by electrostatic.
- ④ The torque for mounting screws should never exceed 0.39N·m (4kgf·cm). Over torque may cause mechanical damage to the product.
- ⑤ Do not press or friction, because LCD panel surface is sensitive. If customers will clean the product surface, NEC Corporation or their supplier will recommend using the cloth with ethanolic liquid.

- ⑥ Do not push-pull the interface connectors while turn on, because wrong power sequence may break down the product.
- ⑦ Connection cables such as flexible cable, and so on, are danger of damage. Do not hook cables nor pull them.

(2) Environment

- ① Dewdrop atmosphere must be avoided.
- ② Do not operate and/or store in high temperature and/or high humidity atmosphere. If customer store the product, keep in antistatic pouch in room temperature, because of avoidance for dusts and sunlight.
- ③ Do not operate in high magnetic field. Circuit boards may be broken down by it.
- ④ Use an original protection sheet on product surface (polarizer). Adhesive type protection sheet should be avoided, because it may change color and/or properties of the polarizer.

(3) Specification for products

- ① Do not display the fixed pattern for a long time because it may cause image sticking. If the fixed pattern is displayed on the screen, use a screen saver.
- ② The product may be changed of color by viewing angle because of the use of condenser sheet for backlight unit.
- ③ The product may be changed of luminance by voltage variation, even if power source applies recommended voltage to backlight inverter.
- ④ Optical characteristics may be changed by input signal timings.

(4) Other

- ① All GND, GNDB and VDD terminals should be connected without a non-connected signal line.
- ② Do not disassemble a product and/or adjust volume.
- ③ If customer would like to replace backlight lamps, see 'REPLACEMENT MANUAL FOR BACKLIGHT'.
- ④ If customer uses screwdrivers, pay attention not to insert waste materials in inside of products.
- ⑤ When customer returns product for repair and so on, pack it with original shipping package because of avoidance of some damages during transportation.
- ⑥ Not only the module but also the equipment that used the module should be packed and transported as the module becomes vertical. Otherwise, there is the fear that a display dignity decreases by an impact or vibrations."

General specifications for the LCD

The following items are neither defects nor failures.

- * **Response time, luminance and color gamut may be changed by ambient temperature.**
- * **The LCD may be seemed luminance uniformity, flicker, vertical seam and/or small spot by display patterns.**
- * **Optical characteristics (e.g. luminance, display uniformity, etc.) gradually is going to change depending on operating time, and especially low temperature, because the LCD has cold cathode fluorescent lamps.**

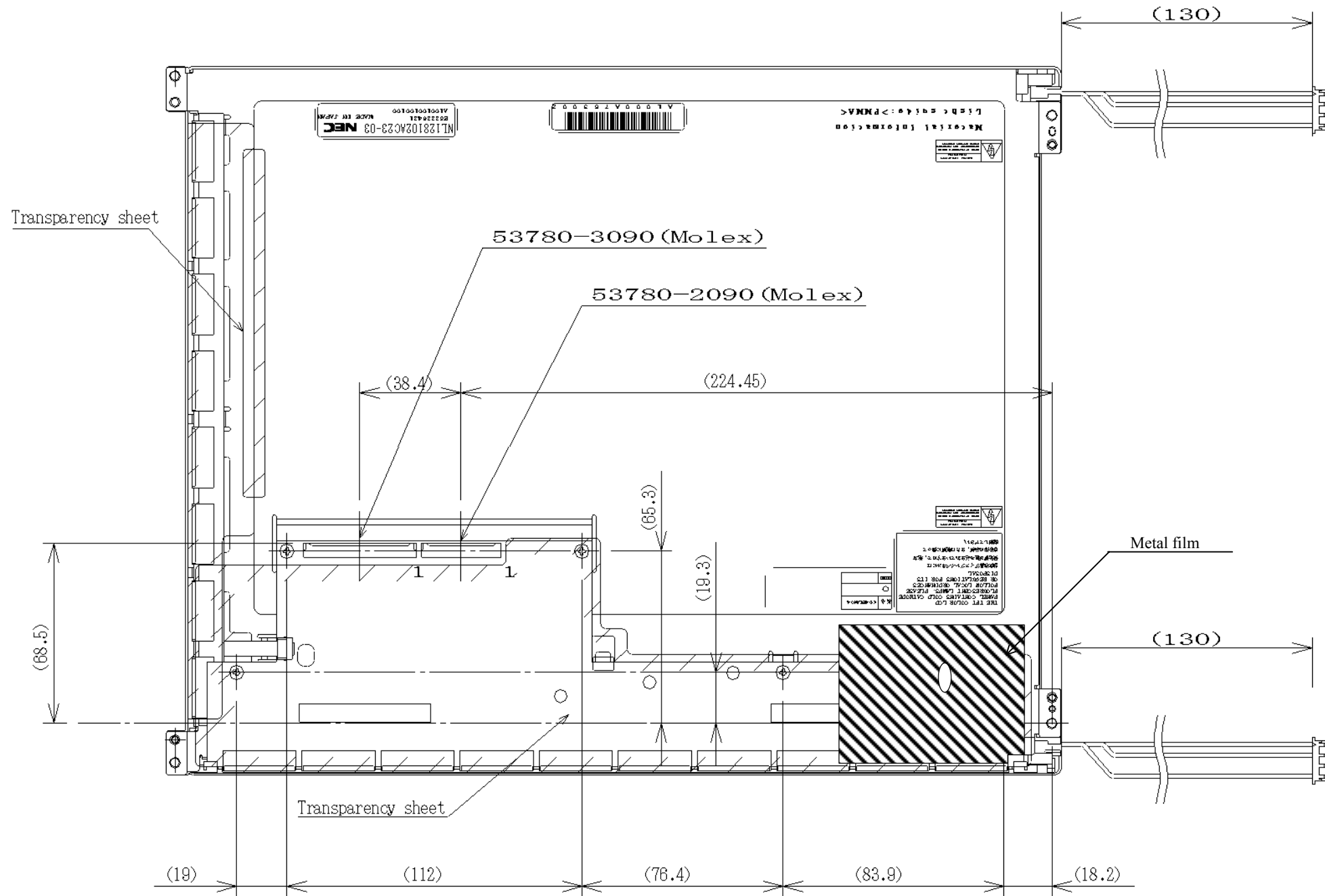

18.2. Rear view



Note 1: The values in parentheses are for reference.

Note 2: The pressure for mounting should never exceed 0.39N·m.

Revision History

Rev.	Prepared date	Revision contents and approval	Signature of writer
1st edition	May 22 2001	<p>DOD-M-0379 Preliminary specifications → Data sheet</p> <p>The inside of this document is revised the clerical error and unclear expression in previous one. The important changes such as specifications, characteristics and functions are as follows.</p> <p>P6 BROCK DIAGRAM: GND is not connected to FG. → GND is connected to FG.</p> <p>P24 Outline drawings - rear view: Metal firm is added.</p>	<p>Approved by</p> <p></p> <hr/> <p>Checked by</p> <hr/> <p>Prepared by</p> <p></p> <hr/>